

PART. NO. 900-0604

SH 1 REV. 01

REV.	SCN NO.	REVISIONS	BY	DATE	APVD.
01		PRELIMINARY RELEASE	MGD	09/18/13	

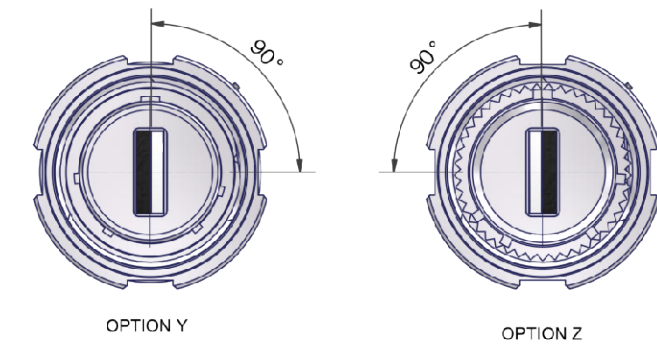
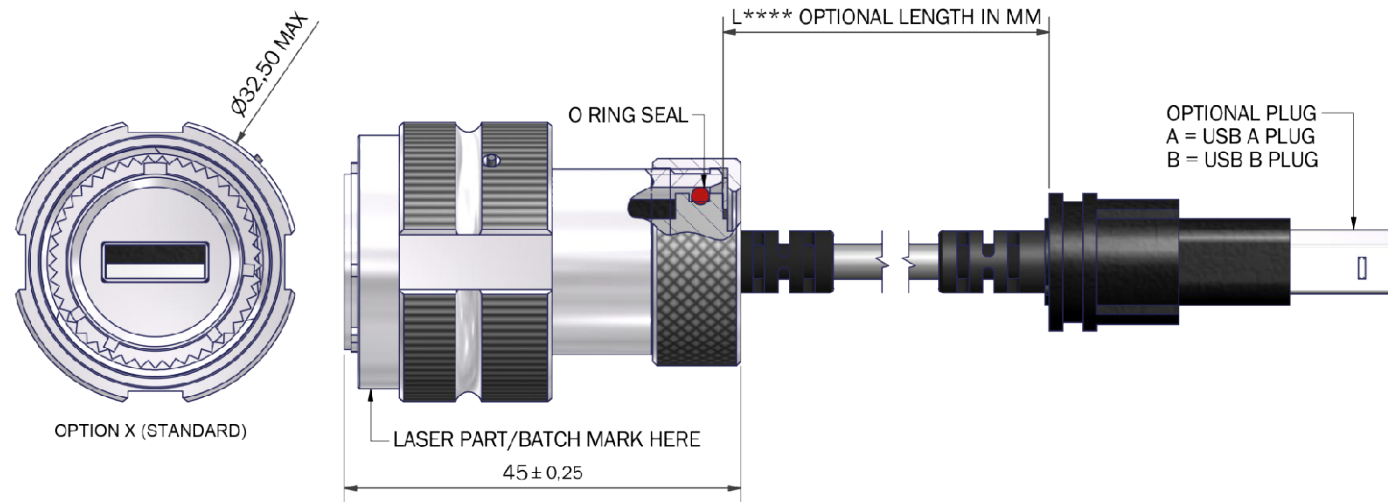

CODE	MATERIAL / PLATING
1-C	ALUMINIUM / ELECTROLESS NICKEL
1-B	ALUMINIUM / CADMIUM OLIVE DRAB OVER ELECTROLESS NICKEL
1-ZB	ALUMINIUM / ZINC COBALT OLIVE DRAB OVER ELECTROLESS NICKEL
4-J	STAINLESS STEEL / PASSIVATE
2-Z	NICKEL ALUMINIUM BRONZE / SHOT BLAST

LIST NOT EXHAUSTIVE. FOR COMPREHENSIVE LIST AND SPECS. SEE WEBSITE

NOTES
 GENERALLY TO THE REQUIREMENTS OF MIL-DTL-38999
 MATES WITH AMPHENOL USBFTV

FINISH
 SEE TABLE

SEAL MATERIAL - SILICONE ELASTOMER

PERFORMANCE
 CURRENT RATING 1 AMP MAX PER CONTACT
 VOLTAGE RATING 30V AC MAX
 TEMPERATURE -40°C TO +105°C

ST4D0021-15NX-1-C-L2000-B

SERIES _____
 SHELL SIZE _____
 KEY ARRANGEMENT (N, A, B, C, D, E) _____
 USB PLUG ROTATION (X, Y, Z) _____
 MATERIAL (SEE TABLE) _____
 PLATING (SEE TABLE) _____
 CABLE LENGTH IN MM (1, 2, 3 AND 5 METRE OPTIONS) _____
 CABLE END OPTION USB A OR B _____

TOLERANCES	DRAWN BY	DATE
.0	M. DECARLO	09/18/13
.00	CHECKED BY	DATE
.000	APPROVED BY	DATE
.0000		
ANGLES		

UNLESS OTHERWISE SPECIFIED ALL DIMENSIONS ARE IN INCHES.
 ALL DIMENSIONS APPLY AFTER PLATING.

PROPRIETARY INFORMATION
 THIS DOCUMENT CONTAINS PROPRIETARY INFORMATION OF STRAN TECHNOLOGIES AND IS DELIVERED ON THE EXPRESSED CONDITIONS THAT IT IS NOT TO BE DISCLOSED OR REPRODUCED IN WHOLE OR PART, OR USED FOR MANUFACTURING FOR ANYONE OTHER THAN STRAN TECHNOLOGIES WITHOUT ITS WRITTEN CONSENT AND THAT NO RIGHT IS GRANTED TO DISCLOSE OR SO USE ANY INFORMATION CONTAINED IN SAID DOCUMENT.



TITLE		
CONN. ASS'Y, USB A CABLED PLUG		
DWG. SIZE	PART NO.	REV.
B	900-0604	01

NEXT ASS'Y	USED ON	APPLICATION

CAGE CODE: 1HVU5 SCALE NONE SHEET 1 OF 1

CUSTOMER USE DRAWING

PART NO. 900-0604 SH 1 REV. 01