

| REV. | SCN NO. | REVISIONS | BY | DATE | APVD. |
|------|---------|---------------------|-----|----------|-------|
| 01 | | PRELIMINARY RELEASE | MGD | 05/13/10 | |

| ASSEMBLY P/N | ASSEMBLY DESCRIPTION |
|--------------|----------------------------------|
| 410-0048-126 | TERMINI, SOCKET, 29504/5, 126 uM |
| 410-0048-173 | TERMINI, SOCKET, 29504/5, 173 uM |

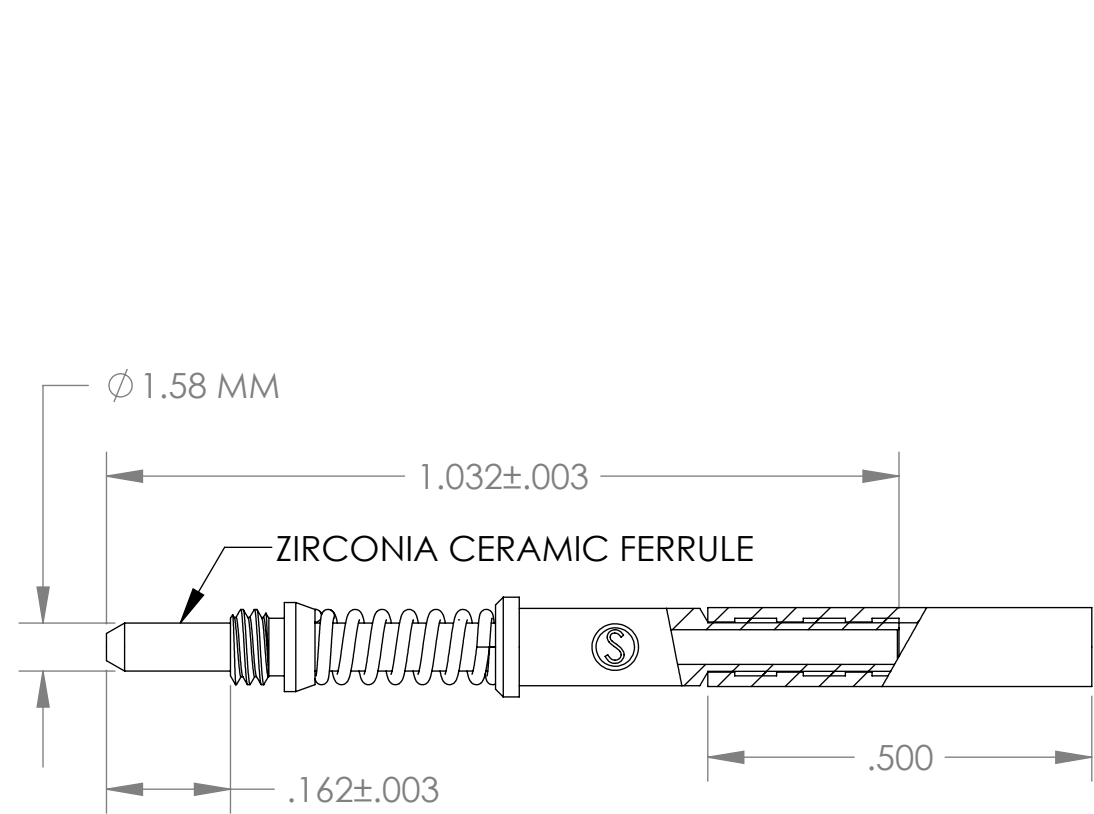

SPLIT SLEEVE & HOOD REMOVED
THIS VIEW

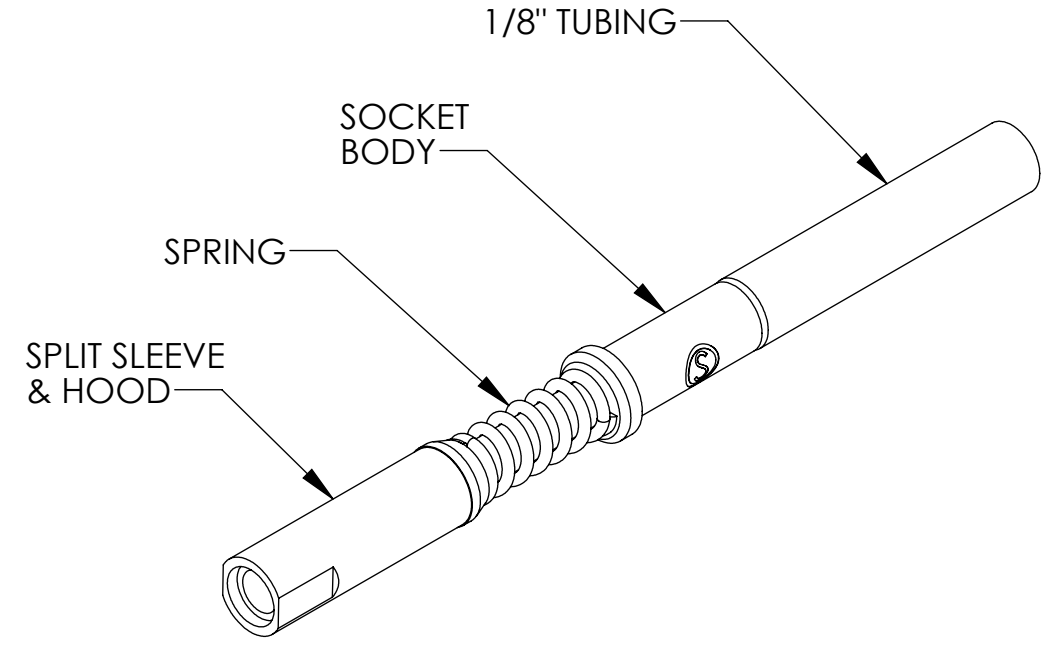

- NOTES:
1. FOR COMMERCIAL USE ONLY.
 2. SOCKET BODY IS 300 SERIES STAINLESS STEEL - PASSIVATED.
 3. ALL DIMENSIONS ARE REFERENCE ONLY.

| | | | | |
|---|--|--|----------------------------------|--|
| TOLERANCES .00 ± - .000 ± - .0000 ± - ANGLES ± - | | DRAWN BY M. DECARLO CHECKED BY APPROVED BY | DATE 05/13/10 DATE DATE | STRAN TECHNOLOGIES 39 GREAT HILL RD NAUGATUCK, CT 06770 |
| UNLESS OTHERWISE SPECIFIED ALL DIMENSIONS ARE IN INCHES. ALL DIMENSIONS APPLY AFTER PLATING. | | | | TITLE TERMINI, SOCKET, 29504/5 |
| PROPRIETARY INFORMATION THIS DOCUMENT CONTAINS PROPRIETARY INFORMATION OF STRAN TECHNOLOGIES AND IS DELIVERED ON THE EXPRESSED CONDITIONS THAT IT IS NOT TO BE DISCLOSED OR REPRODUCED IN WHOLE OR PART, OR USED FOR MANUFACTURING FOR ANYONE OTHER THAN STRAN TECHNOLOGIES WITHOUT ITS WRITTEN CONSENT AND THAT NO RIGHT IS GRANTED TO DISCLOSE OR SO USE ANY INFORMATION CONTAINED IN SAID DOCUMENT. | | DWG. SIZE B | PART NO. 410-0048-XXX | REV. 01 |
| THIRD ANGLE PROJECTION | | CAGE CODE: 1HVU5 | SCALE NONE | SHEET 1 OF 1 |

PART NO. 410-0048-XXX
SH 1
REV. 01