

REV.	SCN NO.	REVISIONS	BY	DATE	APVD.
01		PRELIMINARY RELEASE	MGD	05/13/10	

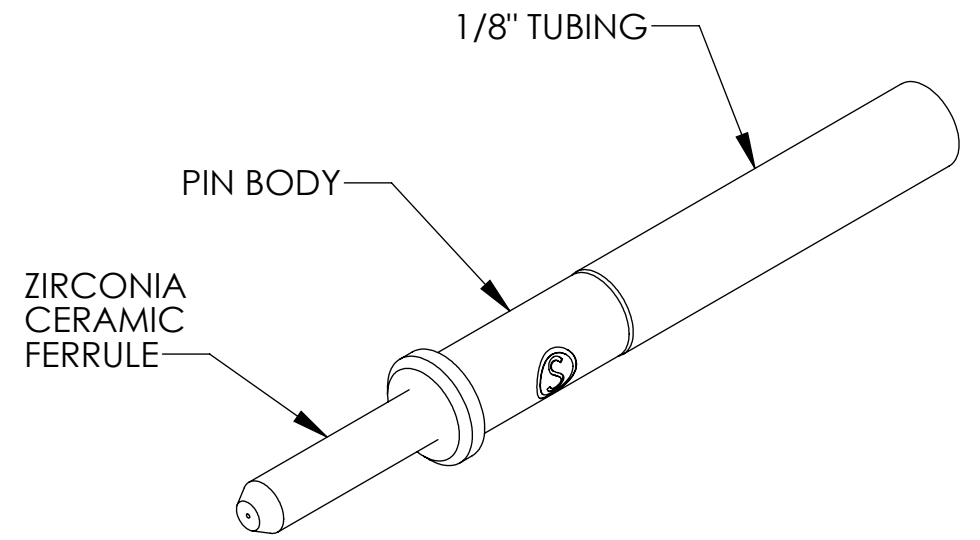
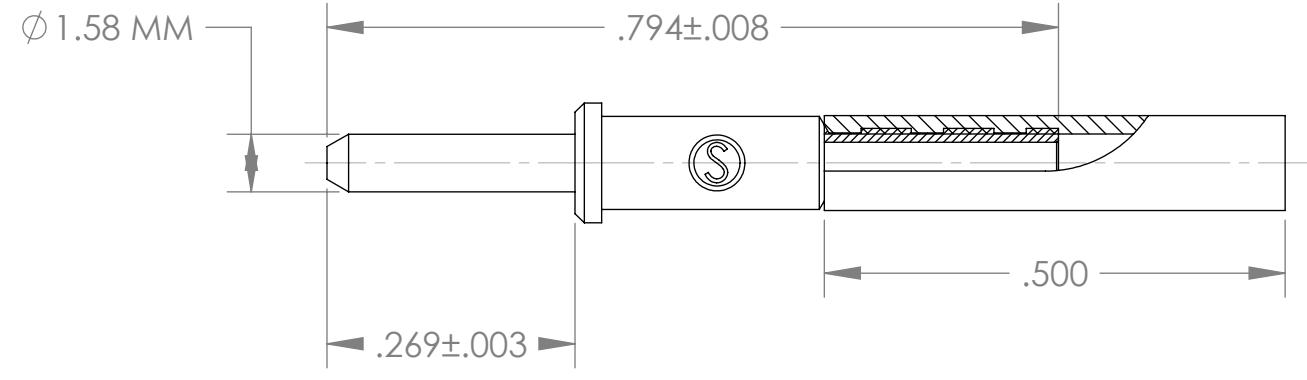

ASSEMBLY P/N	ASSEMBLY DESCRIPTION
410-0047-126	TERMINI, PIN, 29504/4, 126 uM
410-0047-173	TERMINI, PIN, 29504/4, 173 uM

- NOTES:
1. FOR COMMERCIAL USE ONLY.
  2. PIN BODY IS 300 SERIES STAINLESS STEEL - PASSIVATED.
  3. ALL DIMENSIONS ARE REFERENCE ONLY.

<b>TOLERANCES</b> .00 ± - .000 ± - .0000 ± - ANGLES ± -		DRAWN BY <b>M. DECARLO</b> CHECKED BY APPROVED BY	DATE 05/13/10 DATE DATE	<b>STRAN TECHNOLOGIES</b> 39 GREAT HILL RD NAUGATUCK, CT 06770  TITLE <b>TERMINI, PIN,                  29504/4</b>
UNLESS OTHERWISE SPECIFIED ALL DIMENSIONS ARE IN INCHES. ALL DIMENSIONS APPLY AFTER PLATING.		PROPRIETARY INFORMATION THIS DOCUMENT CONTAINS PROPRIETARY INFORMATION OF STRAN TECHNOLOGIES AND IS DELIVERED ON THE EXPRESSED CONDITIONS THAT IT IS NOT TO BE DISCLOSED OR REPRODUCED IN WHOLE OR PART, OR USED FOR MANUFACTURING FOR ANYONE OTHER THAN STRAN TECHNOLOGIES WITHOUT ITS WRITTEN CONSENT AND THAT NO RIGHT IS GRANTED TO DISCLOSE OR SO USE ANY INFORMATION CONTAINED IN SAID DOCUMENT.		
THIRD ANGLE PROJECTION 		DWG. SIZE <b>B</b>	PART NO. <b>410-0047-XXX</b>	REV. <b>01</b>
CAGE CODE: 1HVU5		SCALE NONE	SHEET 1 OF 1	

PART NO. 410-0047-XXX SH 1 REV. 01